



## Smart Box-3

Smart Box-3 insures safe, reliable operation of **progressing cavity pumps**, protecting them from over-pressure, run-dry situations, or seal water failure.

This latest generation Smart Box is versatile, easy to install, easy to use, and compatible with either fixed speed or variable speed pumps.

The Smart Box-3 uses a solid state PLC and touch-screen for maximum reliability, eliminating wiring, mechanical push buttons, and lights. The touch-screen interface displays simple English text so pump status and fault conditions are easy to understand. It comes standard in a fiberglass weatherproof (NEMA-4X) enclosure, with optional stainless steel also available. It operates on 120-230 VAC power and includes its own internal DC power supply.

Working in combination with the Onyx Isolator Ring ensures reliable operation with abrasive slurries, viscous fluids, suspended solids, and corrosive liquids.

Our standard 2-point **solid state pressure switch** with digital readout is easier to set, more robust, and more accurate than traditional mechanical gauges and switches.

Smart Box-3 can be configured as a "Master" controller where all pump commands are routed through the Smart Box. Or, it can be a designated as a "slave" where it ties into the pump control circuit at a single point for simpler wiring.

The Smart Box can be configured to work as a Local Control Station, eliminating the need for an H-O-A (Hand-Off-Auto) switch or Reset button.

The Smart Box can turn seal flush water on and off, and can monitor seal water flow switch.

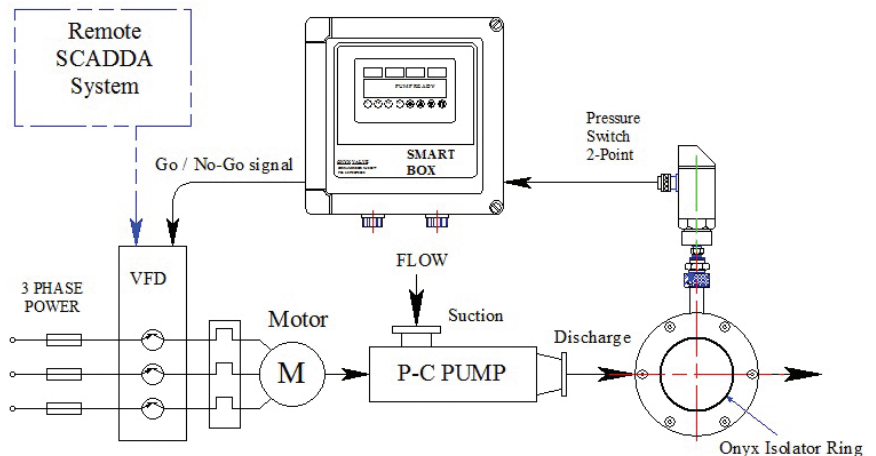

Smart Box General Arrangement  
Closing the Loop

